



Motorsports

OWNER'S MANUAL

Read Instructions Before Using Your New Puma 200



Table of Contents

NOTICE	2
SAFETY GEAR.....	3
MODIFICATION OF VEHICLE.....	3
SPECIFICATIONS.....	4
PARTS & SUBASSEMBLIES.....	5
OPERATION	6
FUEL VALVE.....	6
ENGINE STARTING AND STOPPING.....	7
SWITCHES ON THE RIGHT HANDLEBAR.....	8
CHECK-UPS, ADJUSTMENT AND MAINTENANCE.....	9
CHANGING THE OIL.....	10
CHECK-UP OF SPARK PLUG	10
CHECKING & CLEANING THE AIR FILTER.....	11
ADJUSTING THE THROTTLE CABLE.....	12
ADJUSTMENT OF REAR BRAKE.....	13
ADJUSTMENT OF CHAIN.....	14
GREASING PROCEDURES TO THE DRIVING CHAIN.....	14
VEHICLE WASHING.....	15
INSTRUCTIONS FOR STORAGE	16
RESUMPTION OF SERVICE AFTER STORAGE	17
TABLE AND TORQUE OF FASTENERS	17
MAINTENANCE ROUTINE DIAGRAM.....	18
TROUBLE SHOOTING.....	19
EMISSION CONTROL SYSTEM WARRANTY.....	20

DO NOT RETURN STORE. For questions regarding assembly and use, call Customer Service: 877-441-6999.

NOTICE!

Failure to follow these instructions nullifies any warranty, whether stated or implied.

Before operating your Puma 200 Mini Bike

! Warning! !

A pre-operation check must be conducted, before starting the engine, insure safety, prevent mishaps, and damage to components.

It is strongly suggested that all operators take a certified motorcycle rider's course prior to operating the vehicle.

Full attention is required during driving; paying close attention to the following points to avoid any injury to you by other motorized vehicles:

Do not drive too close to other vehicles.

Never carry a passenger. This mini bike is for one operator only

Never operate this mini bike at night. Night is defined as the period of time 30 minutes before sunset to 30 minutes after sunrise.

Driving at high speeds is the cause of many accidents; do not drive at a speed that the actual situation does not permit.

This user's manual contains important safety and maintenance information. Read it carefully before riding. Failing to follow the warnings contained in this manual could result in INJURY or DEATH.

It is important that this manual remain with the vehicle when you transfer it to another user or owner.

All information, illustrations, photographs and specifications contained in this manual are based on the latest product information available at the time of publication. Due to improvements or other changes, there will be some discrepancies in this manual. We reserve the right to make product changes at any time, without notice and without incurring any obligation to make the same or similar changes to the vehicle previously built or sold.

Always avoid operating this mini bike on paved surfaces, including; sidewalks, paths, parking lots, driveways, streets, roads, and highways. Never operated this or any Off-Road vehicle on a public street, road or highway where motor vehicles are in operation.

DO NOT RETURN STORE. For questions regarding assembly and use, call Customer Service: 877-441-6999.

SAFETY GEAR

1. Never operate this mini bike without wearing a DOT approved motorcycle helmet which fits properly. Operators should also wear eye protection (goggles or face shield), gloves, boots, long-sleeved shirt or jacket, and long pants.
2. Loose clothes are not suitable for motorcycle driving or riding as they may get caught on footrest or wheel, resulting in danger.

MODIFICATION OF THE VEHICLE

CAUTION

Never perform any unauthorized modifications to this vehicle.
Only use original replacement part which can be obtained
through YUKON TRAIL INC. 877-441-6999

DO NOT RETURN STORE. For questions regarding assembly and use,
call Customer Service: 877-441-6999.

SPECIFICATIONS

Description	Data	Description	Data
Overall length	1680mm (66.14 inch)	Cylinder bore x stroke	6.8cm X 15.41cm (2.68" X 2.13")
Overall width	800.1mm (31.5 inch)	PTO shaft rotation	Counter clockwise
Overall height	979.9mm (38.58 inch)	Output, max	6.5hp at 3600 rpm
Wheelbase	1162mm (45.75 inch)	Torque, max	9.76 ft-lbs. at 2500 rpm
Dead weight	64.46 kg (142.1lbs.)	Idling speed	1400 +200 -150
Payload	91kg (200 lbs)	Displacement of cylinder	197cc
Front wheel	19 X 7 - 8 10psi	Spark plug	MEIYA -F7RTC, NGk- BPR6ES, Champion - RN9YC
Rear wheel	19 X 7 - 8 10psi	Spark plug gap	0.7mm -0.79mm (.028"-.031")
Brake Type	Drum	Gap of air valve IN	0.15 +- .02mm (cold)
Capacity of gasoline tank	4.2L (.95 gal.)	Gap of air valve EX	0.20+- .02mm (cold)
Capacity of oil tank	.5L (.53 qt.)	Ground clearance	139 mm (5.5")
Drive	Centrifugal clutch	Ignition means	Magneto

DO NOT RETURN STORE. For questions regarding assembly and use,
call Customer Service: 877-441-6999.

PARTS & SUBASSEMBLIES

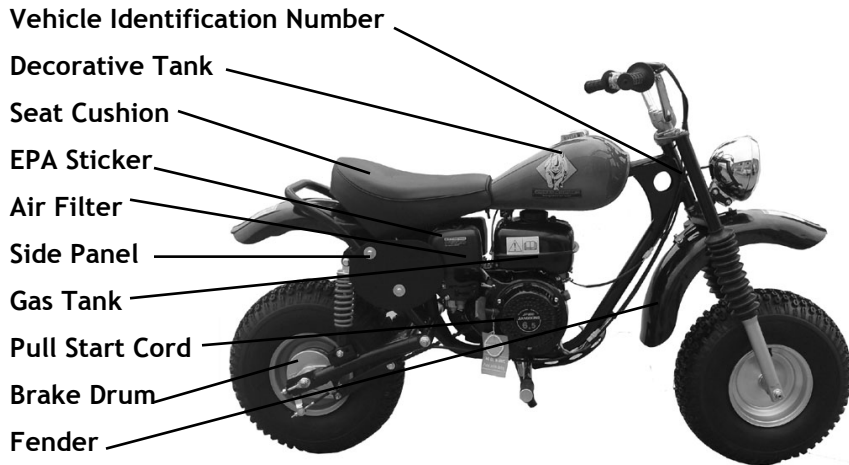
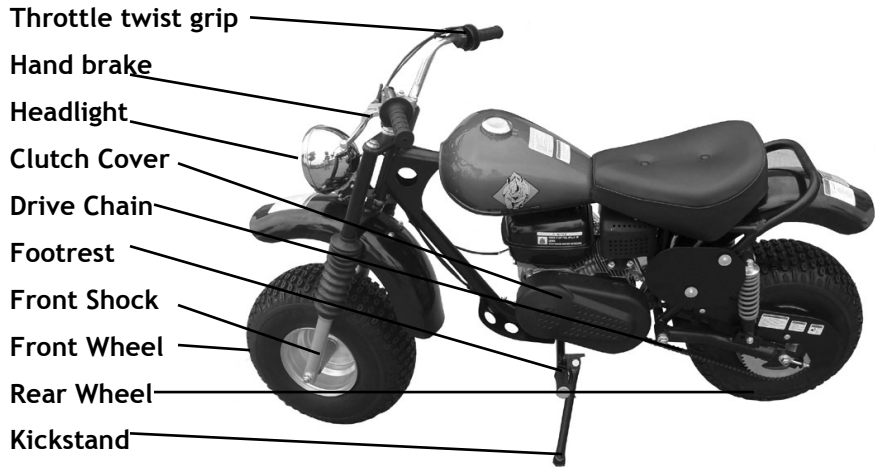

DO NOT RETURN STORE. For questions regarding assembly and use, call Customer Service: 877-441-6999.

OPERATION

FUEL VALVE

Fuel filling

The capacity of the fuel tank is 4.2L (.95 gal). Unscrew the gas cap by turning it counter clockwise and carefully fill the tank with unleaded gasoline through the opening. **DO NOT MIX GAS AND OIL TOGETHER, THIS IS A 4-STROKE ENGINE.** Replace the gas cap by carefully aligning the threads on the cap and the tank and turning the cap clock wise. Wipe any spilled fuel from the dirt bike using a cloth and dispose of the cloth properly. **DO NOT SMOKE OR REFUEL THE VEHICLE NEAR OPEN FLAMES OR NEAR HEATING UNITS. ONLY REFUEL THE VEHICLE IN OPEN AREAS TO REDUCE THE LIKELIHOOD OF THE BUILD UP OF GASOLINE FUMES.**

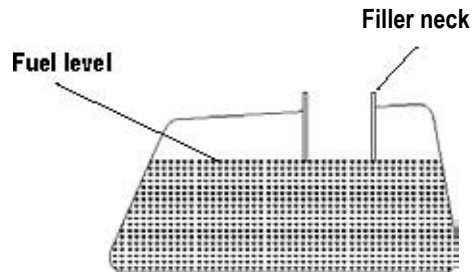

Operation of the fuel valve (the valve under the fuel tank)

ON: With the handle of the fuel valve to "ON" position, the fuel supply will flow to the carburetor.

OFF: With the handle of the fuel valve to "OFF" position, the fuel supply is cut off to the carburetor.

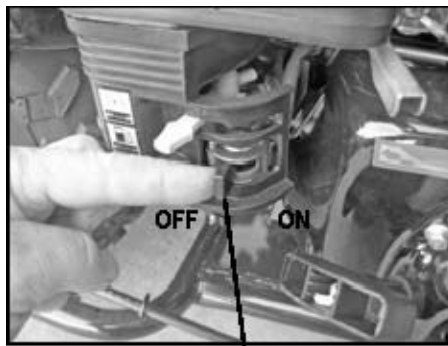

Fuel valve Handle

DO NOT RETURN STORE. For questions regarding assembly and use, call Customer Service: 877-441-6999.

CAUTION

Verify oil level prior to starting (see page 11)
Starting the engine with low or no oil will damage the engine.

ENGINE STARTING AND STOPPING

▲ WARNING

Never start the engine in a closed place as the exhausted gas from the vehicle contains toxic carbon monoxide.

Starting Engine:

1. Place fuel valve lever to "ON" Position.
2. Place Choke lever to "ON" Position.
3. Set the ignition switch to "⊙" Position.
4. Pull the Start Recoil cord until engine starts.
5. After engine has sufficiently warmed up, place Choke lever in "OFF" Position.

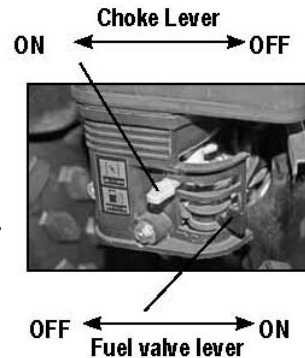

Procedures for stopping engine:

1. Release throttle twist grip to slow down engine.
2. Set the ignition switch to "⊗" position.
3. Set the fuel valve lever (the fuel tank valve) handle to "OFF"

CAUTION

Unnecessarily increasing RPM's to a high level while the Mini Bike is warming up is harmful to the engine.

DO NOT RETURN STORE. For questions regarding assembly and use, call Customer Service: 877-441-6999.

SWITCHES ON RIGHT HANDLEBAR

Ignition switch

The ignition switch is provided on the right handlebar.

When the switch is turned to “” (off) position, the engine will not start or stops the engine.

When the switch is turned to “” (on) position, the engine can start and the vehicle can be driven.

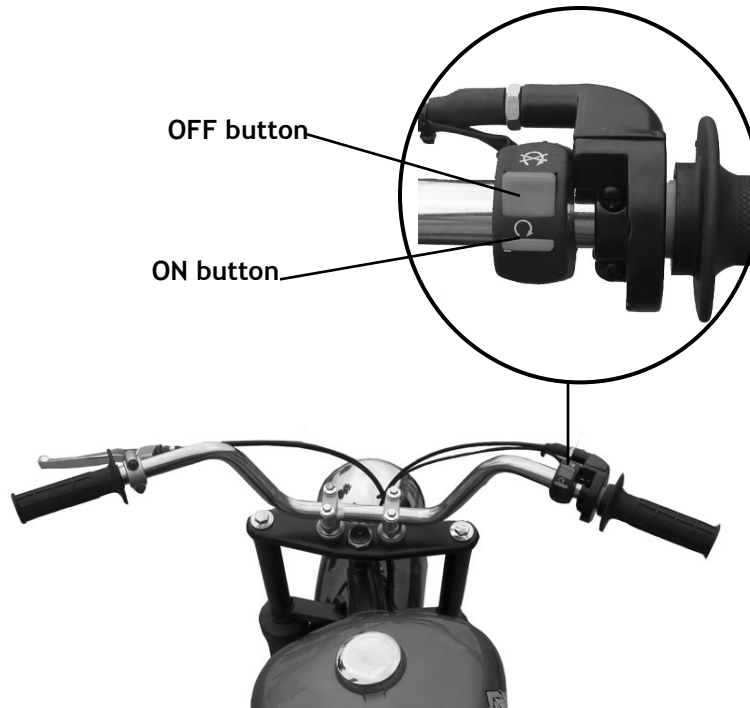

DO NOT RETURN STORE. For questions regarding assembly and use, call Customer Service: 877-441-6999.

—CHECK-UPS, ADJUSTMENT AND MAINTENANCE —

Checking the Oil

Check the engine oil each time prior to operating the mini bike.

The oil level should be between the upper and lower lines of the oil gauge.

1. Set the Mini Bike on level ground, screw off the oil gage plug, wipe the oil gage rod clean and then insert the gage plug into the crankcase again to check the oil level. There is no need to screw the oil gage plug into its hole in the crankcase.

2. Add lubricating oil up to the edge of the fill plug.

3. Finally screw in the oil gage plug tightly.



Oil dip stick

CAUTION

Never start the engine when there is insufficient lubricating oil. Otherwise, it will cause harm to the engine.

Lubricating Oil Recommended

The lubricating oil is an important factor affecting the performance and service life of the engine. Please refer to the chart for the correct grade of engine oil based on the environmental conditions in your area. Do not use any other type of oil other than what is recommended in the chart. **DO NOT MIX OIL WITH THE GASOLINE.**

Lubricating oils of different viscosity shall be employed in different regions and at different temperatures.

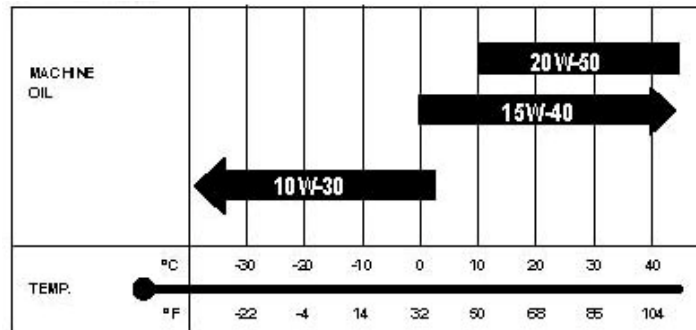

DO NOT RETURN STORE. For questions regarding assembly and use, call Customer Service: 877-441-6999.

CHANGING THE OIL

1. Remove the “Screw Plug” located at the bottom of the engine and let the oil drain into an approved collection container. **DO NOT PERFORM THIS PROCEDURE WHILE THE ENGINE IS HOT. SERIOUS BURNS COULD RESULT FROM CONTACT WITH HOT OIL.**
2. Dispose of the used oil properly
- 3 Clean and replace the “Screw Plug” tightly. Torque to 18 ft.lb.
4. Refill the engine with 0.53 qt. (0.5L) of recommended oil and recheck the amount of oil in the engine by using the oil gauge plug.



Screw plug for oil draining



CHECK-UP OF SPARK PLUG

1. Remove the cap of spark plug and screw off the spark plug using the plug wrench.
2. Clean the spark plug all around or replace it if it is corroded or there is too much deposit on it.
3. Regulate the gap of the spark plug to .7mm - .79mm (.028”-.031”).
4. The spark plug of the designated type should be used. The applicable type of spark plug: Meiya - F7RTC
Champion-RN9YC, NGK - BPR6ES



DO NOT RETURN STORE. For questions regarding assembly and use, call Customer Service: 877-441-6999.

CHECKING & CLEANING THE AIR FILTER

1. Remove seat to access air filter. Seat is removed by removing nut located under seat (see photo).
2. Locate Air Filter Box under seat and remove cover.
3. Remove air filter.
4. Remove foam cover from Air filter element.
5. Tap the Air filter element gently to remove most of the dust and dirt. Blow out remaining dust with compressed air. If the element is damaged, replace it.
6. Wash the foam element cover per instructions below then allow to dry thoroughly.
7. Reinstall foam cover to the air filter element.
8. Reinstall air filter and close cover.

Seat nut

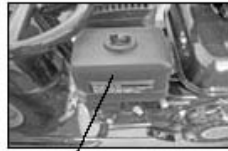

Air Filter box

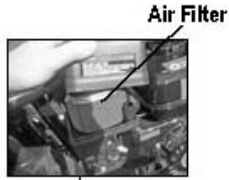

Removal of cover

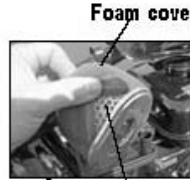

Removal of filter

Air filter element



Wash with mild soap and water



Rinse with fresh water then squeeze out excess.

CAUTION

The air filter element must be intact or the engine will suck in dust and dirt, resulting in a shorter service life of the engine.

Water should be prevented from entering into the filter when washing the vehicle.

The filter element shall be cleaned gently without twisting to prevent it from cracking. Never wash it with gasoline or any acid, alkaline or organic volatile oil to avoid its aging, which will result in reducing the effect of the air filter oil to catch particles before they enter the engine. Replace the filter element with a new one if it is broken or cracked.

DO NOT RETURN STORE. For questions regarding assembly and use, call Customer Service: 877-441-6999.

ADJUSTING THE THROTTLE CABLE

Make sure the throttle cable is adjusted properly. To adjust throttle cable, rotate adjustment nut located at the hand throttle.

Check if the throttle twist grip has the required free operating movement.

The required free operating movement: 2-6mm (.078 -.24in) . If the grip cannot be moved freely, turn the adjusting nut to ensure proper operating movement.

After adjustment, start the engine and check for the operating movement again. Repeat the adjustment if necessary until the desired operating movement is obtained.

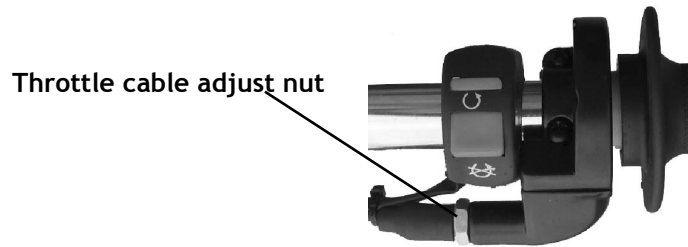

DO NOT RETURN STORE. For questions regarding assembly and use, call Customer Service: 877-441-6999.

ADJUSTMENT OF REAR BRAKE

1. The front brake hand grip should have free operating movement of 5-7mm (.2-.3in).
2. To make adjustment, turn rear adjusting nut clockwise to reduce and counterclockwise to increase the free operating movement of the hand brake.
3. Brake shoes should be replaced by a qualified service technician once brake shoes are worn.

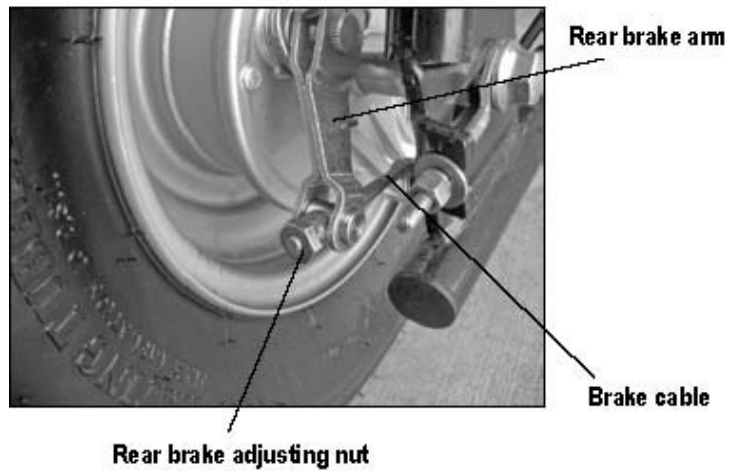
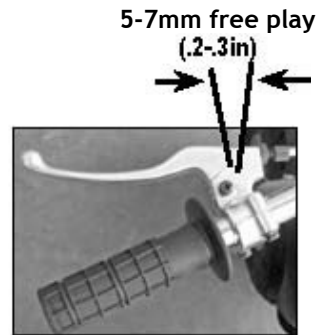

DO NOT RETURN STORE. For questions regarding assembly and use, call Customer Service: 877-441-6999.

ADJUSTMENT OF CHAIN

- 1 When chain adjustment is needed, loosen rear axle bolt .
- 2 Turn the chain adjusting nuts on the left and right sides to adjust the tension of the chain and to align the marking of the chain adjuster with the engraved lines in the similar position on both sides.
- 3 Tighten rear axle bolt by a torque of 50-60Nm (37-44 ft.lb.).
- 4 Repetitively check the tension of the chain.

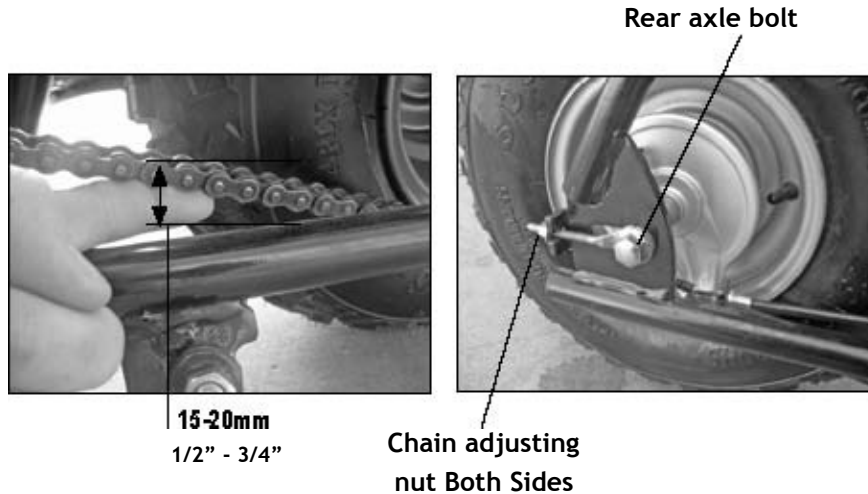

GREASING PROCEDURES TO THE DRIVING CHAIN

- 1 Shut off the engine
- 2 Add light amounts of machine oil or chain grease to the driving chain. (Too much machine oil or chain grease may cause splattering to occur.)

Attention:

The chain should be replaced when the adjusting limit has reached it's maximum.

DO NOT RETURN STORE. For questions regarding assembly and use, call Customer Service: 877-441-6999.

VEHICLE WASHING

Cleaning the vehicle regularly can slow down the color fading of its body and make it easier to check if there is any damage and any oil leakage.

CAUTION

Washing the Mini Bike with over-pressurized water may cause damage to some of its components. Therefore, do use a pressure washer to clean the vehicle. The following parts should be cleaned using low pressure water:

- Wheel hub
- Exhaust pipe
- Fuel tank and lower portion of cushion
- Carburetor
- Head lock and ignition switch
- Meters

- 1 After pre-wiping, the vehicle should be washed with clean water to remove dirty residues so as to prevent corrosion. Plastic subassemblies should be cleaned by wiping with a cloth or foam soaked in neutral detergent solution, followed by washing with clean water.
- 2 After the cleaned vehicle is air dried, grease the chain and run the engine at idling speed for a few minutes.
- 3 Prior to driving, carefully check the braking system repeatedly and repair or adjust it if necessary.

DO NOT RETURN STORE. For questions regarding assembly and use, call Customer Service: 877-441-6999.

INSTRUCTIONS FOR STORAGE

If the vehicle is not going to be used for a long period of time, for example, in winter time, some steps should be taken to prevent malfunction of and damage to its components which might be caused by long storage. Before storing the vehicle for a long period, proper maintenance has to be carried in case maintenance is not completed when the vehicle is put back into use after storage.

- 1 Change engine oil.
- 2 Drain off fuel from the fuel tank and carburetor, spray atomized anti-rust oil onto the inside wall of the tank and then close the tank. Dispose of any drained fuel properly so as not to adversely affect the environment.

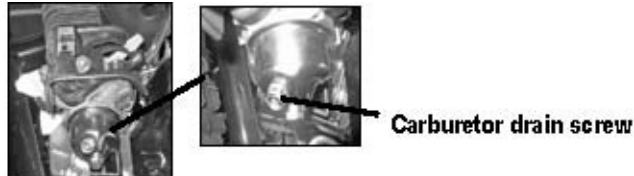

Attention:

If the storage will last for more than one month, fuel in the carburetor must be fully drained. This will help ensure that the carburetor maintains its normal performance after the storage.

⚠ WARNING

Gasoline is flammable and may cause fire and even an explosion under certain conditions. Therefore, do not smoke, make a fire or have any fire around while draining off fuel.

3. Take out the spark plug, pour about 15-20ml (.5 - .68 oz.) of clean engine oil into the cylinder, step down on the kick lever repetitively several times so as to have machine oil distributed all over the engine and finally fit the spark plug back on.
4. Wash the vehicle clean, wipe it dry and apply an even coat of wax to the painted surface and a coat of anti-rust oil on the chrome-plated surfaces.
5. Inflate the tires as required and put the vehicle up on wooden blocks with the two wheels clearing the ground.
6. Put the vehicle in a shady and cool place free from humidity and direct sunlight and cover it properly (not with plastic or other painted materials). If there is a garage, store it within.

DO NOT RETURN STORE. For questions regarding assembly and use, call Customer Service: 877-441-6999.

SERVICE AFTER STORAGE

1. Remove the covering and remove the wooden blocks used in storing the vehicle. Change the engine oil if the vehicle has been out of service for over 4 months.
2. Drain off the remaining atomized anti-rust oil from the fuel tank, followed by filling it with fresh gasoline therein.
3. Prior to driving, all the required check-ups must be made. It is better to drive it at a low speed in an open area to test its performance before normal operation.

TABLE AND TORQUE OF FASTENERS

Ser. No.	Fastener	Torque (Newton/m) (Foot/lb)
1	Front wheel axle nut	35-45Nm (26-33 ft.lb.)
2	Rear wheel axle nut	50-60Nm (37-44 ft.lb.)
3	Front Fork Bolts	45-47.5Nm (33-35 ft.lb)

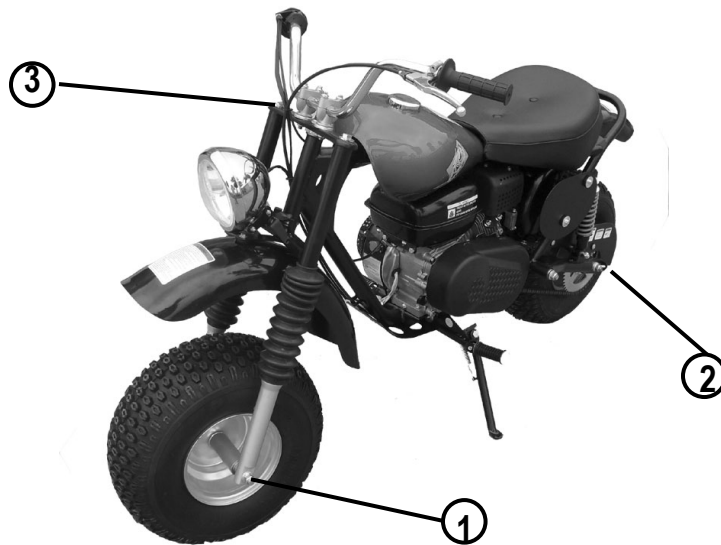

DO NOT RETURN STORE. For questions regarding assembly and use, call Customer Service: 877-441-6999.

MAINTENANCE SCHEDULE

ITEM OF MAINTENANCE	EA. USE	1ST MO./20 HRS.	EVERY 3 MO./50 HRS.	EVERY 6 MO./100 HRS.	EVERY YR./300 HRS.
Engine oil-Check	X				
*Engine oil-Change		X		X	
Air filter-Check	X				
*Air filter-Clean			X	X	
*Air filter-Change					X
*Carburetor sediment cup-Clean				X	
Spark plug-Check-Adjust				X	
Spark plug-Replace					X
Idle speed-Check-Adjust					X
**valve clearance-Check-Adjust					X
Fuel tank and filter-Clean				X	
Fuel tube-Check					X
Front shock bolts-Tighten to spec.	X				
All nuts and bolts-Check for tightness	X				
Chain tension-Check	X				
*Brakes-Check	X				
*Throttle-Check	X				
*Throttle cable-Check	X				

“*” means: This item of maintenance should be carried out at a service center. It may be also done by the user with reference to this manual provided special tools and authorized spare parts are used. The user must also be capable of completing the procedure.

“**” means: This item can only be carried out by an authorized service center in order to ensure safety.

Notes:

1. Maintenance should be conducted more frequently when Mini Bike is driven in dusty areas.
2. When Mini bike has exceeded the maximum figures specified in the table, maintenance should be still cycled according to the intervals of time or hours stated herein.

DO NOT RETURN STORE. For questions regarding assembly and use, call Customer Service: 877-441-6999.

TROUBLESHOOTING

Engine will not Start

1. Fuel valve OFF	Move Fuel valve lever to ON.
2. Choke OPEN	Move Chock Lever to CLOSED
3. Out of fuel	Refuel
4. Bad fuel; engine stored without treating or draining gasoline, or refueled with bad gasoline	Drain fuel and carburetor. Refuel with fresh gasoline
5. Spark plug faulty, fouled, or improperly gapped	Remove and inspect spark plug. Clean, gap, or replace
6. Spark plug wet with fuel (flooded engine)	Remove and inspect spark plug. Dry and reinstall spark plug.
7. Fuel filter clogged, carburetor malfunction, ignition malfunction, valves stuck, etc.	Take the engine to a qualified mechanic. Replace or repair faulty components as necessary

Engine Lacks Power

1. Filter element (s) clogged	Check air filter Clean or replace.
2. Bad fuel; engine stored without treating or draining gasoline, or refueled with bad gasoline.	Drain fuel tank and carburetor. Refuel with fresh gasoline.
3. Fuel filter clogged, carburetor malfunction, ignition malfunction , valves stuck, etc.	Take engine to a qualified mechanic. Replace or repair faulty components as necessary.

DO NOT RETURN STORE. For questions regarding assembly and use, call Customer Service: 877-441-6999.

WARRANTY REGISTRATION

RETURN THE PUMA 200 MINI BIKE PRODUCT REGISTRATION
WITH A COPY OF YOUR SALES RECEIPT TO :
Yukon Trail, Inc. 4142 Pacific Privado, Ontario, CA 91761

Name: _____
Address: _____
City: _____ State: _____ Zip _____
Phone: _____ E-mail: _____
Date Purchased: _____ Model#: _____
Store Where Purchased: _____
Store Address: _____
Receipt or Transaction #: _____

The registration must be returned to Yukon Trail, Inc. within 10 days of purchase. It is the only information Yukon Trail will have for notification to you of any information regarding this product.

This information is for the sole purpose of product/registration and will not be sold or used for any other purpose.

A COPY OF THE SALES RECEIPT AND UPC BAR CODE MUST BE INCLUDED WITH THIS REGISTRATION CARD.

Thank you for purchasing an Yukon Trail, Inc. Puma 200 Mini Bike. If there are parts missing or if your Puma 200 Mini Bike does not run properly, do not return your Puma 200 Mini Bike to the place of purchase. Please call Yukon Trail, Customer Service at 877-441-6999

PLEASE DO NOT RETURN PRODUCT TO RETAILER FOR WARRANTY OR REPLACEMENT PARTS.

*or register online at www.yukontrailinc.com using the warranty link or fax to 877-443-9284



Yukon Trail, Inc.

LIMITED WARRANTY

Your Puma 200 Mini Bike is warranted to be free of manufacturing defects in material or workmanship for a period of 90 days. During the warranty period Yukon Trail, Inc. will at its option, repair, provide replacement parts or replace your Puma 200 Mini Bike at no charge. This warranty does not cover normal wear and tear, or damage caused by neglect, or misuse of the product.

Should you experience a problem or need to return your Puma 100 Mini Bike for repair, please call the Yukon Trail customer service department TOLL FREE AT 877-441-6999 between the hours of 9AM and 4PM PST Monday thru Friday. You will be instructed how to proceed. A copy of receipt is required. You may also contact Yukon Trail, Inc. by writing.

Yukon Trail, Inc.
Ontario, CA 91761
Or
www.yukontrailinc.com

Made in China